

www.swiftdentalsupply.com

Tel: (562) 242-8684 / (661) 333-9705

swiftdentalsupply@gmail.com



				
Order No.	HG07F	HG06F	HG03F	HG10F
Dimensions(mm)	25*2	20*1	4*13	12*2







Order No.	Dimensions	Place
DB53520	85mm*0.35mm*20mm	1





SWIFT DENTAL SUPPLY

Grinding and Finishing Burs Catalog

					
Order No.	G13	G45	G20	G11	G33
Dimensions (mm)	6*21	5*17	4.5*13	13*2.0	13*7.0

							
Order No.	SD001	SD002	SD003	SD004	SD005	SD006	SD007
Size e 1/10mm	060	060	060	060	050	030	050

				
Order No.	HP07C	HP06C	HP03C	HP10C
Dimensions(mm)	25*2	20*1	4*13	12*2

				
Order No.	HP07F	HP06F	HP03F	HP10F
Dimensions(mm)	25*2	20*1	4*13	12*2

Diamond Turbo Grinder



The diamond grinder system with the extraordinary grinding properties, extremely long service life and thus maximum efficiency due to high grade diamond and binding material. They can cut through Zirconia with a minimal amount of pressure thus alleviates the chance of micro fractures within the Zirconia substructure.



- Fine Grit
- 8000-15000 rpm
- max:25000 rpm
- 1 pc



Order No.	TG01	TG02	TG03	TG06	TG07
Size c 1/10mm	0.65	050	045	160	220
Length in mm	13.0	13.0	13.0	1.5	2.0

- Fine Grit
- 8000-15000 rpm
- max:25000 rpm
- 1 pc



Order No.	TG08	TG09	TG10	TG11	TG12
Size c 1/10mm	220	150	130	220	150
Length in mm	4.5	3.5	2.0	2.0	2.0





- Extra Fine
- 8000-15000 rpm
- max:25000 rpm
- 1 pc

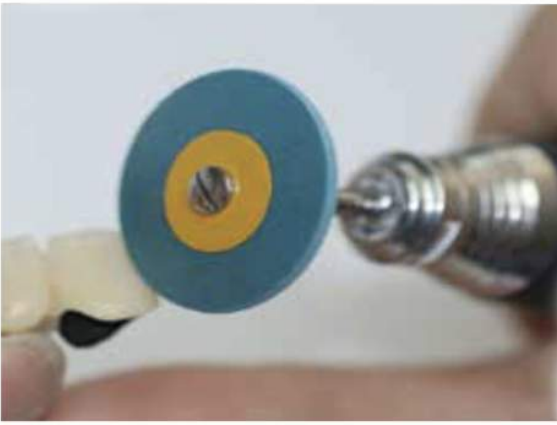

Order No.	TF10	TF02	TF03
Size c 1/10mm	130	050	045
Length in mm	2.0	13.0	13.0



3 steps diamond polishing system used to restore a natural high shine to all kind of ceramics and metals, High concentration diamond grits make more efficiency, Special formula ensure long service, odorless

 medium
 7000-15000 rpm
 max:20000 rpm
 1pc



Order No.	HP07C	HP06C	HP03C	HP10C
Dimensions(mm)	26*2	20*1	4*13	12*2

 fine
 7000-15000 rpm
 max:20000 rpm
 1pc



Order No.	HP07F	HP06F	HP03F	HP10F
Dimensions(mm)	26*2	20*1	4*13	12*2

Separating Discs & Roughing wheels



Special dual-bonded resin binder ensure maximum durability and performance, odorless
 Each product has its own characteristics and is designed for specific purpose

Separating Discs (Aluminum Oxide)

“Fast-cutting!” , for all non-precious metals and cobalt chrome economically, highest durability



Order No.	Dimensions	Piece
380718	38mm*0.7mm	100

Order No.	Dimensions	Piece
350718	35mm*0.7mm	100

Order No.	Dimensions	Piece
250618	25mm*0.6mm	100
251018	25mm*1.0mm	50

Roughing wheels (Aluminum Oxide)

Optimum processing of chrome cobalt frame via very aggressive grinding properties



Order No.	Dimensions	Piece
381018	38mm*1.0mm	50
381718	38mm*1.7mm	40

Order No.	Dimensions	Piece
351018	35mm*1.0mm	50
351718	35mm*1.7mm	40
353018	35mm*3.0mm	25

Order No.	Dimensions	Piece
322218	32mm*2.2mm	35

Separating Discs (Silicon Carbide)

For precious alloys, ceramics without leaving mark



Order No.	Dimensions	Piece
220618C	22mm*0.6mm	100

Order No.	Dimensions	Piece
220218	22mm*0.25mm	100





Aluminum Oxide reinforced discs

For non-precious and partial denture alloys. Very stable even in case of lateral pressure load and high speed.

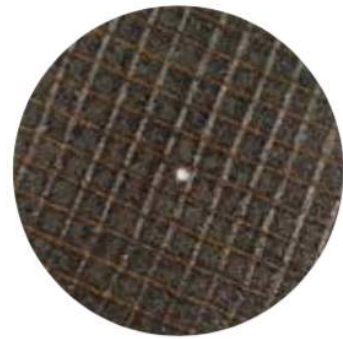

Order No.	Dimensions	 Piece
400518R	40mm*0.5mm	20
400718R	40mm*0.7mm	20
401018R	40mm*1.0mm	20



Order No.	Dimensions	 Piece
380718R	38mm*0.7mm	20
381018R	38mm*1.0mm	20



Order No.	Dimensions	 Piece
250618R	25mm*0.6mm	20

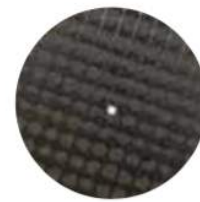

Order No.	Dimensions	 Piece
220318R	22mm*0.3mm	20

Silicon carbide reinforced discs

For separating and finishing ceramic safety



Order No.	Dimensions	 Piece
220318CR	22mm*0.3mm	20



Order No.	Dimensions	 Piece
220218CR	22mm*0.2mm	20

Diamond reinforced discs

Fully interspersed with diamond particles. For porcelain, Zirconia and lithium disilicate.



Order No.	Dimensions	 Piece
220318DR	22mm*0.3mm	20

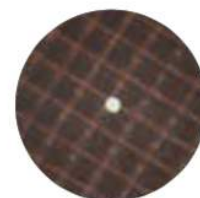

Order No.	Dimensions	 Piece
220218DR	22mm*0.2mm	20

2 steps diamond polishing system for Lithium Disilicate from smoothing to high gloss polishing .making glazing unnecessary High concentration diamond grits make more efficiency, Special formula ensure long service, odorless

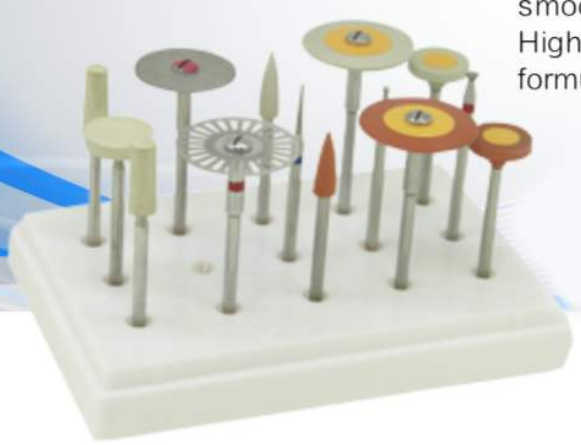

- medium
- 7000-15000 rpm
- max:20000 rpm
- 1pc



Order No.	HB07M	HB06M	HB03M	HB10M
Dimensions(mm)	26*2	20*1	4*13	12*2

- fine
- 7000-15000 rpm
- max:20000 rpm
- 1pc



Order No.	HB07F	HB06F	HB03F	HB10F
Dimensions(mm)	26*2	20*1	4*13	12*2

2 steps diamond polishing system for Zirconia from smoothing to high gloss polishing .making glazing unnecessary, High concentration diamond grits make more efficiency, Special formula ensure long service, odorless

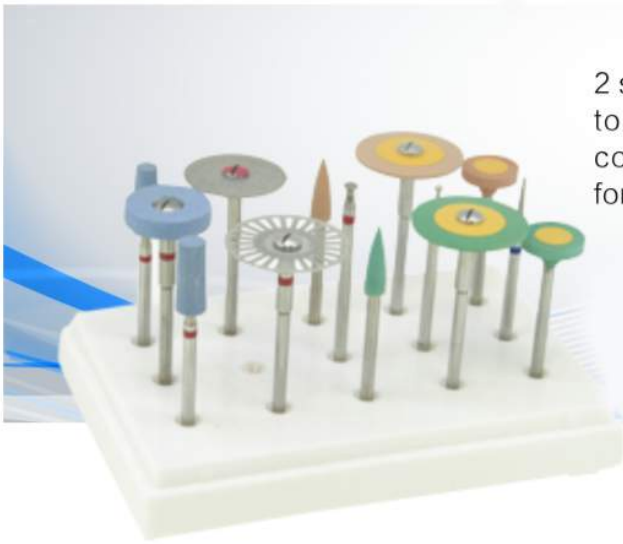

- medium
- 7000-15000 rpm
- max:20000 rpm
- 1pc



Order No.	HG07M	HG06M	HG03M	HG10M
Dimensions(mm)	26*2	20*1	4*13	12*2

- fine
- 7000-15000 rpm
- max:20000 rpm
- 1pc



Order No.	HG07F	HG06F	HG03F	HG10F
Dimensions(mm)	26*2	20*1	4*13	12*2

Sintered Diamonds



More durable than conventional stones
Efficient cutting and self-cleaning , Faster finishing



- Supercoarse grit
- 10000–15000 rpm
- max:20,000rpm
- 1 pc



Order No.	SD301	SD302	SD303	SD304	SD305
Size ϵ 1/10mm	060	060	060	060	050

- Supercoarse grit
- 10000–15000 rpm
- max:20,000rpm
- 1 pc



Order No.	SD307	SD308	SD309	SD310	SD313
Size ϵ 1/10mm	050	050	040	050	080

- Coarse grit
- 10000–15000 rpm
- max:20,000rpm
- 1 pc



Order No.	SD101	SD102	SD103	SD104	SD105	SD107	SD110
Size ϵ 1/10mm	060	060	060	060	050	050	050

- Medium grit
- 10000–15000 rpm
- max:20,000rpm
- 1 pc



Order No.	SD201	SD202	SD204	SD205	SD207	SD210	SD213
Size ϵ 1/10mm	060	060	060	050	050	050	080

- Medium grit
- 10000–15000 rpm
- max:20,000rpm
- 1 pc



Order No.	SD222	SD223	SD224	SD225	SD226
Size ϵ 1/10mm	016	016	016	016	016



-  Fine grit
-  10000-15000 rpm
-  max:20,000rpm
-  1 pc

Order No.	SD001	SD002	SD003	SD004	SD005	SD006	SD007
Size \varnothing 1/10mm	060	060	060	060	050	030	050



-  Fine grit
-  10000-15000 rpm
-  max:20,000rpm
-  1 pc

Order No.	SD008	SD009	SD010	SD011	SD012	SD013
Size \varnothing 1/10mm	050	040	050	080	040	080



-  Fine grit
-  10000-15000 rpm
-  max:20,000rpm
-  1 pc

Order No.	SD021	SD022	SD023	SD024	SD025	SD026
Size \varnothing 1/10mm	016	016	016	016	016	016



-  Extra Fine
-  10000-15000 rpm
-  max:20,000rpm
-  1 pc

Order No.	SD401	SD402	SD403	SD404	SD405	SD406	SD407
Size \varnothing 1/10mm	060	060	060	060	050	030	050



-  Extra Fine
-  10000-15000 rpm
-  max:20,000rpm
-  1 pc

Order No.	SD408	SD409	SD410	SD411	SD412	SD413
Size \varnothing 1/10mm	050	040	050	080	040	080

Flexible Diamond Discs



For the fine separation of porcelain and resin veneers. Very flexible.

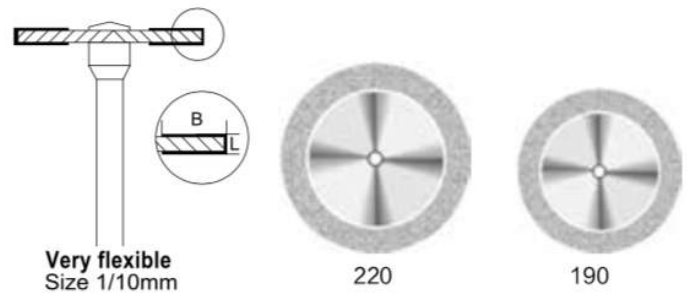
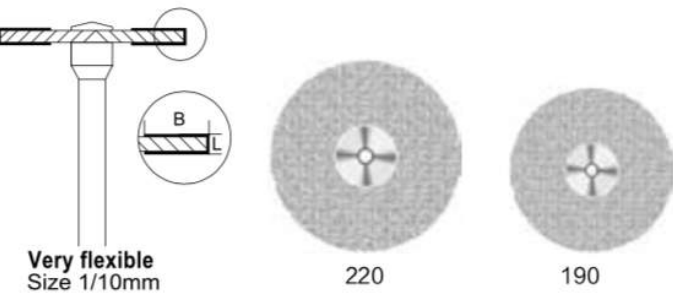

Order No.	■ FD2217	■ FD1917
Head L in mm	0.17	0.17
coating B	Double sided full	Double sided full

Order No.	■ FD2217A	■ FD1917A
Head L in mm	0.17	0.17
coating B	Double sided 3mm	Double sided 3mm

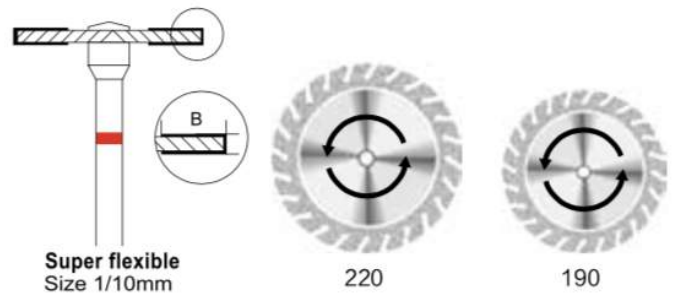
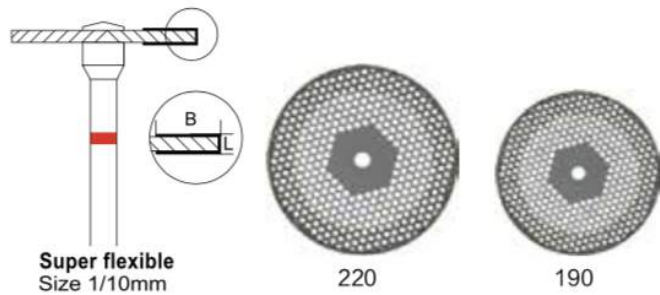

Order No.	■ FD2215	■ FD1915
Head L in mm	0.15	0.15
coating B	Double sided full	Double sided full

Order No.	■ FD2215A	■ FD1915A
Head L in mm	0.15	0.15
coating B	Double sided 3mm	Double sided 3mm

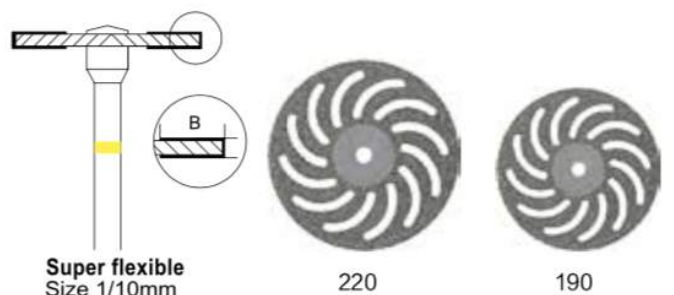
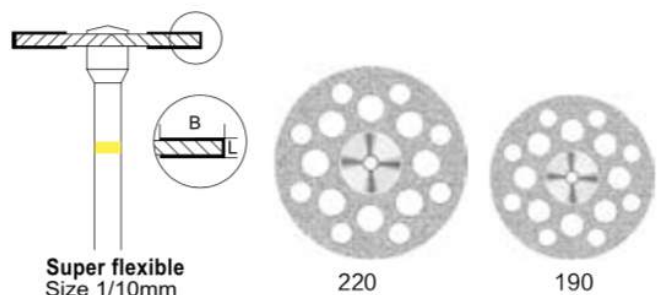

Order No.	■ FD2212K	■ FD1912K
Head L in mm	0.12	0.12
coating B	Double sided full	Double sided full

Order No.	■ FD2212X	■ FD1912X
Head L in mm	0.12	0.12
coating B	Double sided full	Double sided full

■ Fine Grit 45um

■ Extra-fine Grit 30um

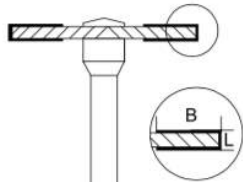

Very flexible
Size 1/10mm



220

Order No.	■ FD2217B	■ FD2222B
Head L in mm	0.17	0.22
coating B	Double sided full	

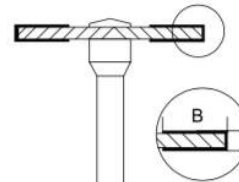

flexible
Size 1/10mm



Order No.	■ FD1922D
Head L in mm	0.22
coating B	Double sided 3mm

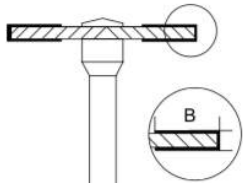

flexible
Size 1/10mm



220

Order No.	■ FD2222A	■ FD2230A
Head L in mm	0.22	0.30
coating B	Double sided 3mm	

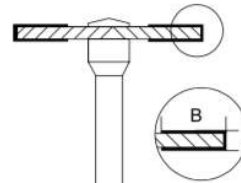

flexible
Size 1/10mm



190

Order No.	■ FD1922A	■ FD1930A
Head L in mm	0.22	0.30
coating B	Double sided 3mm	

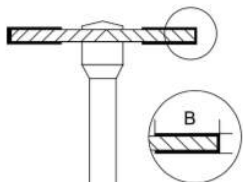

flexible
Size 1/10mm



220

Order No.	■ FD2222	■ FD2230
Head L in mm	0.22	0.30
coating B	Double sided full	

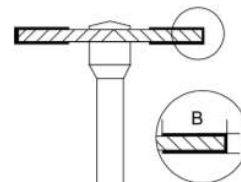

flexible
Size 1/10mm



190

Order No.	■ FD1922	■ FD1930
Head L in mm	0.22	0.30
coating B	Double sided full	



Flexible Sintered Diamond Discs



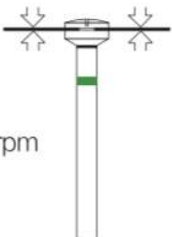

Flexible for separating ceramic and cutting surfaces on ceramic, precious metals, non-precious alloys and all zirconia







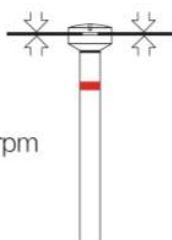

-  Medium grit
- 10000-20000 rpm
- max:
-  1 pc

Order No.	SH393	SH391
Diameter	22mm	19mm
Thickness	0.30mm	0.30mm



-  Fine Grit
- 10000-20000 rpm
- max:
-  1 pc

Order No.	SH394	SH392
Diameter	22mm	19mm
Thickness	0.20mm	0.20mm

cleaning stone

For the cleaning and refreshing of diamond instruments particularly if you change use from metals to ceramics



- Cleaning stone for sintered diamonds

Multilayer Diamond Burs



Selected natural diamond grit and advanced electroplating processing technics ensure products highest durability and sharpness



Order No.	MA27	MA24	MK30	MD27
Size \varnothing 1/10mm	027	023	030	027



Order No.	MD15	MRZ3	MP18	MJ17
Size \varnothing 1/10mm	015	033	018	018



Order No.	FP18	FJ17	FRZ3	FK30
Size \varnothing 1/10mm	018	018	033	030

Silicon polishers for ceramic

3 steps silicone polishers for removing scratches and smoothing the surface on all types of porcelain

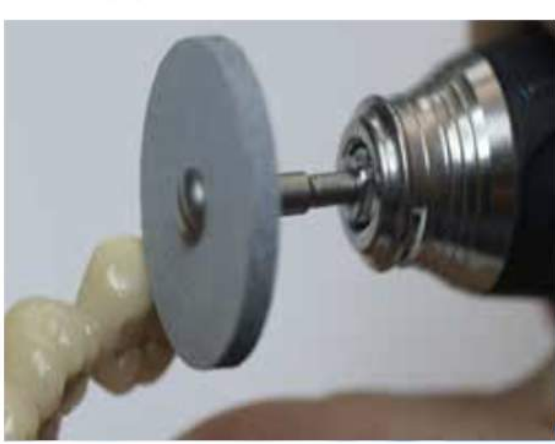

-  coarse
-  7000-15000 rpm
-  max:25000 rpm
-  100pieces

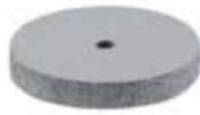

Order No.	SP223C	SP221C	SP622C
Dimensions(mm)	22*3	22*1.0	6*22

-  medium
-  7000-15000 rpm
-  max:25000 rpm
-  100pieces



Order No.	SP223M	SP221M	SP622M
Dimensions(mm)	22*3	22*1.0	6*22

-  fine
-  7000-15000 rpm
-  max:25000 rpm
-  100pieces



Order No.	SP223F	SP221F	SP622F
Dimensions(mm)	22*3	22*1.0	6*22

Rubber polishers

Rubber polishers for cobalt-chrome, non-precious and semi-precious alloy



- coarse
- 15000–25000 rpm
- max:35000 rpm
- 100pieces



Order No.	RM221C	RM223C	RM622C
Dimensions(mm)	22*1.0	22*3	6*22

- medium
- 15000–25000 rpm
- max:35000 rpm
- 100pieces



Order No.	RM221M	RM223M	RM622M
Dimensions(mm)	22*1.0	22*3	6*22

- fine
- 15000–25000 rpm
- max:35000 rpm
- 100pieces



Order No.	RM221F	RM223F	RM622F
Dimensions(mm)	22*1.0	22*3	6*22

Silicon polishers for Acrylic

3 steps silicone polishers for adjusting and polishing denture acrylics

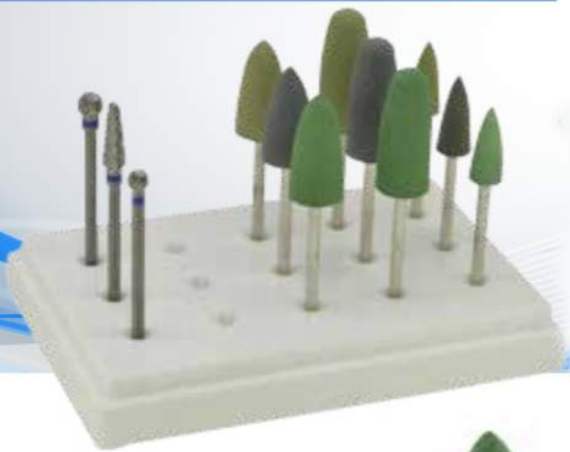

- coarse
- 5000-7000 rpm
- max:15000rpm
- 100pc



Order No.	S1020C	S1024C	S0616C	S0517C
Dimensions(mm)	10*20	10*24	6*16	5*17

- medium
- 5000-7000 rpm
- max:15000rpm
- 100pc



Order No.	S1020M	S1024M	S0616M	S0517M
Dimensions(mm)	10*20	10*24	6*16	5*17

- fine
- 5000-7000 rpm
- max:15000rpm
- 100pc



Order No.	S1020F	S1024F	S0616F	S0517F
Dimensions(mm)	10*20	10*24	6*16	5*17

Plaster Discs

Special processing with natural diamond and stiff steel, vibration-free

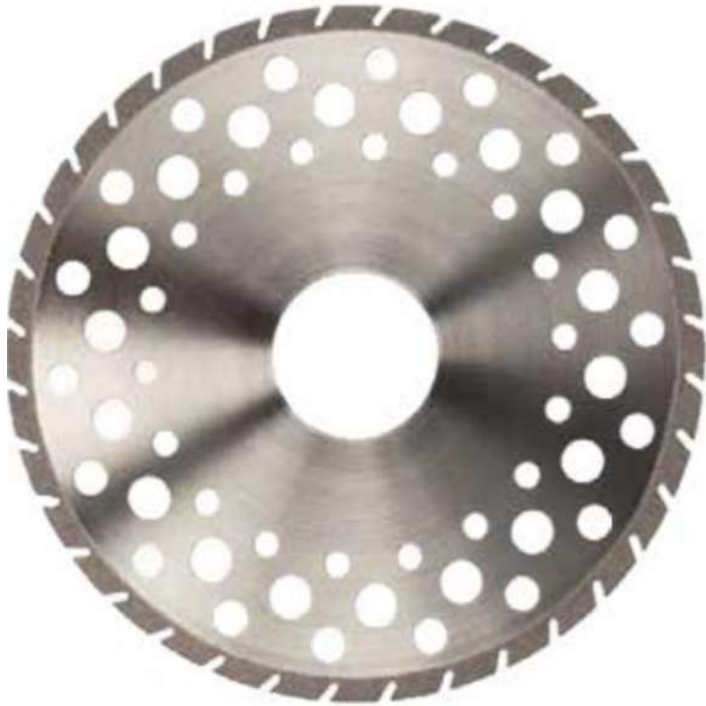
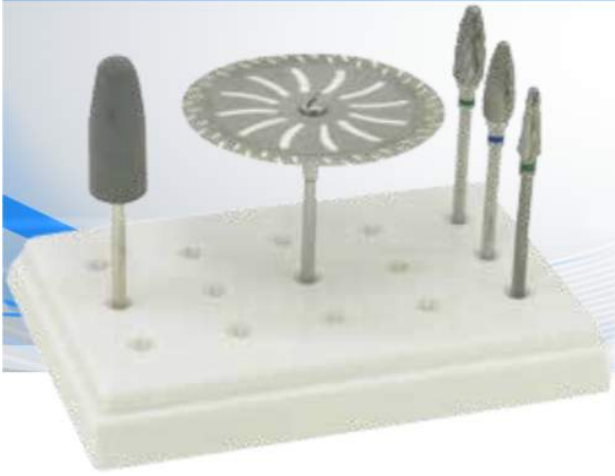

Order No.	Dimensions	Piece
D853520	85mm*0.35mm*20mm	1

Order No.	Dimensions	Piece
D903020	90mm*0.30mm*20mm	1



Order No.	Dimensions	Piece
D453518	45mm*0.35mm*1.8mm	1

Order No.	Dimensions	Piece
D353018	35mm*0.30mm*1.8mm	1

Universal polishers



For smoothing all dental materials, including porcelain, acrylics and precious metal

- ☼ coarse
- 7000-10000 rpm
- max:20000 rpm
- ☼ 100pieces



Order No.	SU223C	SU221C	SU622C
Dimensions(mm)	22*3	22*1.0	6*22

- ☼ coarse
- 7000-10000 rpm
- max:20000 rpm
- ☼ 100pieces



Order No.	SU515C	SU516C	SU112C
Dimensions(mm)	6*16	5*17	12*2

Mounted Point Stone



Excellent processing performance
Concentric, vibration-free rotation
Long lasting



For fast processing partial denture cobalt-chrome and non-precious alloys

-  coarse
-  15000-25000 rpm
-  max:35000rpm
-  100pc



Order No.	M13	M1	M2
Dimensions (mm)	6*21	8*16	6*13

Silicon Carbide Standard grit for processing of ceramics and metal

-  medium
-  15000-25000 rpm
-  max:35000rpm
-  100pc



Order No.	G13	G45	G20	G11	G33
Dimensions (mm)	6*21	5*17	4.5*13	13*2.0	13*7.0

Made of pure aluminum oxide, or non-precious metalststal

-  medium
-  15000-25000 rpm
-  max:35000rpm
-  100pc



Order No.	W13	w1	w20	w11
Dimensions (mm)	6*21	8*16	4.5*13	13*2.0

Made of pure aluminum oxide for precious metals and other metals



-  fine
-  15000-25000 rpm
-  max:35000rpm
-  100pc



Order No.	P45	P20	P11
Dimensions (mm)	5*17	4.5*13	13*2.0

Accessories

Stainless steel mandrels

<p>HP/050</p>  <table border="1" style="margin-left: auto; margin-right: auto;"> <tr> <td style="background-color: #ADD8E6;">Head dia</td> <td style="background-color: #ADD8E6;">5.0 mm</td> </tr> <tr> <td style="background-color: #ADD8E6;">Order NO.</td> <td style="background-color: #ADD8E6;">SS50</td> </tr> </table>	Head dia	5.0 mm	Order NO.	SS50	<p>HP/080</p>  <table border="1" style="margin-left: auto; margin-right: auto;"> <tr> <td style="background-color: #ADD8E6;">Head dia</td> <td style="background-color: #ADD8E6;">8.0 mm</td> </tr> <tr> <td style="background-color: #ADD8E6;">Order NO.</td> <td style="background-color: #ADD8E6;">SS80</td> </tr> </table>	Head dia	8.0 mm	Order NO.	SS80	<p>FG Adapter</p>  <table border="1" style="margin-left: auto; margin-right: auto;"> <tr> <td style="background-color: #ADD8E6;">Order NO.</td> <td style="background-color: #ADD8E6;">SS23</td> </tr> </table>	Order NO.	SS23
Head dia	5.0 mm											
Order NO.	SS50											
Head dia	8.0 mm											
Order NO.	SS80											
Order NO.	SS23											

Diamond polishing paste



5g, 20g

Order No.	DP2	DP3
usage	composite	All ceramics

Mini felt wheels

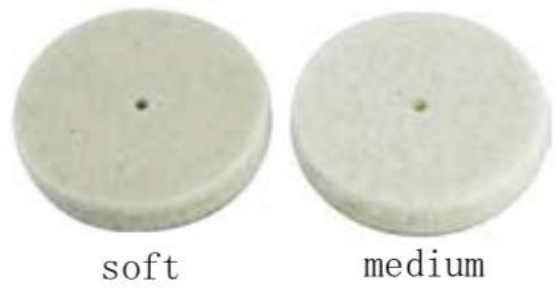

Order No.	2504	2505
Dimensions (mm)	25*4	25*5